

AERO-TECH GREEN JET

DRY-WETCLEANING MACHINE: MODEL DWC-45

MAXIMUM LOAD CAPACITY		45 lbs. (20.4 kgs)
ELECTRICAL: 208/60/3 50 Maximum Running Amps 240/60/3 44 Maximum Running Amps Circuit Breaker, 3 Phase		60 Amps
COMPRESSED AIR: ½ Inch NPT Pipe		5 HP 18 cfm @ 90 psi
VENT DUCT: Diameter *		6 in.*
DIMENSIONS: Width (Including hose connections) Depth (Including back, door, and bumper) Height		48 in. (121.9 cm) 42 in. (106.7 cm) 89 in. (226.1 cm)
DIMENSIONS STRIPPED: Width Depth Height		46.5 in. (118.1 cm) 37 in. (94.0 cm) 70 in. (177.8 cm)
WEIGHT: Empty Shipping		1020 lbs. 1100 lbs.

* Use 8 inch diameter duct for exhausts that exceed 20 feet with 2 or more elbows.

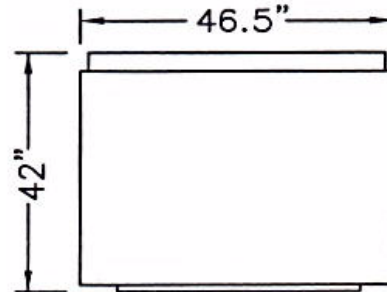
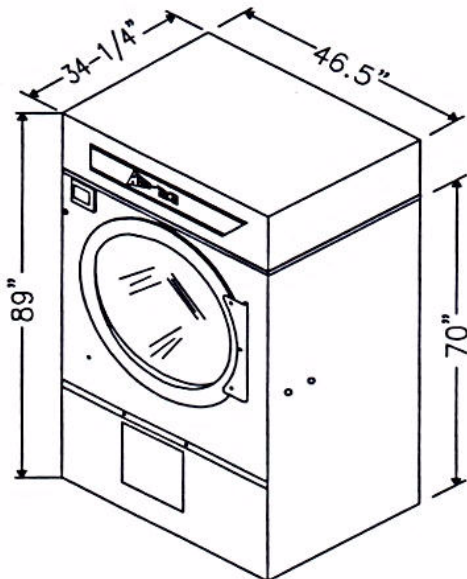

TOP VIEW